

**Jefferson County School District, No. R-1
Support Services Division**

TECHNICAL GUIDELINES 2007

**DIVISION 27 – Communications
February 28, 2008**

DIVISION 27 COMMUNICATIONS

27 05 13 Communication Services - May 25, 2007

- Work in this Division is restricted to vendors pre-approved by Jefferson County School District, R-1:
- Work in this section is restricted to specific products of specific manufacturers that have been previously approved by Jefferson County School District, R-1 Facilities Services and Telecommunication Departments.
 1. Dial tone services are provided for the District by Qwest
 2. T1 services for the District are provided by Qwest
 3. Television cable services are provided by Comcast
 4. DSL Services: Only in special circumstances
 5. Satellite services: Only in special circumstances
 6. QMOE services are provided by Qwest
- Definitions
 1. CAP: Converged Application Platform
 2. COTS: Commercial Off The Shelf
 3. Comcast: Video supplier
 4. PM: Jefferson County School District, R-1 Construction Project Manager
 5. District Telecommunication Department / Enterprise Operations
 6. EC: Electrical Contractor
 7. GC: General Contractor
 8. IDF: Intermediate Distribution Frame
 9. MDF: Main Distribution Frame
 10. OTDR: Optical Time Domain Reflectometer
 11. PRI: Primary Rate Interface
 12. PSTN: Public Switched Telephone Network
 13. QMOE: Qwest Metropolitan Optical Ethernet
 14. Qwest: Phone and T1 supplier
 15. RBOC: Regional Bell Operations Company
 16. TBB: Telecommunications Bonding Backbone
 17. TGB: Telecommunications Ground Bus Bar
 18. TPM: Telecommunications Project Manager
- Coordination
 1. See 'Responsibility Matrix' at the end of this Division
- Warranty Term
 1. All materials and installation shall be guaranteed to be free from defects in materials and workmanship after final acceptance of installation for a period of one year from the date of final acceptance, unless otherwise noted.

END SECTION 27 05 13

27 05 26 Grounding and Bonding for Communications Systems - May 25, 2007

- Work in this section is restricted to specific products of specific manufacturers that have been previously approved by Jefferson County School District, R-1.
- See Section 27 06 00 – Schedules for Communications

Jefferson County School District, R-1 TECHNICAL GUIDELINES 2007
Division 27 – Communications

- See Data, Communications, and Alarm Diagram.
- All District facilities shall be equipped with a telephone communications bonding backbone (TBB).
 1. Electrical contractor will supply and install all grounding to telecommunications closets (MDF and IDF).
 2. This backbone shall be used to ground all telecommunications cable shields, equipment, racks, cabinets, raceways, and other associated hardware that has the potential for acting as a current carrying conductor.
 3. The TBB shall be installed independent of the buildings electrical and building ground and shall be designed in accordance with the recommendations contained in the ANSI/TIA/EIA-607 TMGB.
- The main entrance facility/equipment room in each building shall be equipped with a telecommunications main grounding bus bar (TGB) in MDF.
 1. Each telecommunications closet shall be provided with a TGB in IDF.
 2. The TGB shall be connected to the building electrical entrance grounding facility.
 3. The intent of this system is to provide a grounding system that is equal in potential to the building electrical ground system.
- All racks, metallic backboards, cable sheaths, metallic strength members, splice cases and cable trays, entering or residing in the Telecommunication Room shall be grounded to the respective TGB or TBB using a minimum #6 AWG stranded copper bonding conductor and compression connectors.
 1. Where metallic panels attached to the rack do not have sufficient metal to metal contact to provide an adequate path to ground, they shall be bonded to the rack using a minimum #14 AWG copper conductor.
 2. The copper conductor size shall be upgraded based on the largest power conductor feeding any rack mount equipment.
 3. The conductor shall be continuous; attaching all isolated components in a daisy chain fashion from top to bottom and bonded to the rack using an appropriate compression connector.
- Insulated wires used for telecommunications grounding purposes shall be identified with a green insulation.
 1. Non-insulated wires shall be identified at each termination point with a wrap of green tape.
 2. All cables and bus bars shall be identified and labeled in accordance with the District's labeling standard.
- The TBB shall be designed and approved by a licensed engineer.
 1. The TBB shall be installed in accordance with best industry practices.
 2. A licensed electrician shall perform installation and termination of the main bonding conductor to the building service entrance ground, at a minimum.

END SECTION 27 05 26

27 05 28 Pathways for Communications Systems (Data and Voice) - May 25, 2007

- Work in this section is restricted to specific products of specific manufacturers that have been previously approved by Jefferson County School District, R-1 Telecommunications Department.
- See Section 27 06 00 – Schedules for Communications.
- Coordination
 1. Empty raceway for special systems may or may not be under separate contract.
 2. See Data, Communications and Alarm Diagram.
 3. Contract Documents must clearly define and specify responsibilities to Furnish Rough-In / Install / and Connect:
 - a. Outlet boxes – by Electrical Contractor
 - b. Punch down blocks – by Telecommunications Contractor
 - c. Equipment racks – by Telecommunications Contractor
 - d. Empty raceway – by Electrical Contractor
 - e. Voice cable – by Telecommunications Contractor
 - f. Data cable – by Telecommunications Contractor
 - g. RJ11 connectors – by Telecommunications Contractor
 - h. RJ45 connectors – by Telecommunications Contractor
 - i. F connectors for video connection – by Telecommunications Contractor
- In the absence of other information, standards of the following organizations apply:
 1. ANSI/TIA/EIA 568A-5, Enhanced Category 5
 2. ANSI/TIA/EIA-568A Commercial Building Telecommunications Cabling Standard
 3. ANSI/EIA/TIA-569 Commercial Building Standard for Telecommunications Pathways and Spaces
 4. ANSI/EIA/TIA-606 Administration Standard for the Telecommunications Infrastructure of Commercial Buildings
 5. ANSI/EIA/TIA-607 Commercial Building Grounding and Bonding Requirements for Telecommunications
 6. Building Industries Consulting Services International (BICSI) Telecommunications Distribution Methods Manual (TDMM)
- Cabling
 1. Cables shall be installed in continuous lengths from origin to destination (no splices) unless specifically addressed in this guideline.
 2. The cable's minimum bend radius and maximum pulling tension shall not be exceeded.
 3. Any cable damaged or exceeding recommended installation parameters during installation shall be replaced by the vendor prior to final acceptance at no cost to the District.
 4. All cable shall be labeled at both ends via tape labels and/or a indelible ink marking pen and in a manner agreed upon by the District and the installer.
 5. Support horizontal cables at a maximum of five-foot intervals.

Jefferson County School District, R-1 TECHNICAL GUIDELINES 2007
Division 27 – Communications

6. At no point shall cable(s) rest on acoustic ceiling grids or panels or any other support systems such as lighting, fire alarm, plumbing, or heating ducts.
 7. Cable plant will be run in its own support system.
 8. Cable shall be installed above fire-sprinkler systems and shall not be attached to the system or any ancillary equipment or hardware.
 9. The cabling system and support hardware shall be installed so that it does not obscure any valves, fire alarm conduit, boxes, or other control devices.
 10. Any bundle that has more than 5 cables in it will be supported by a cable saddle or Arlington Loop.
 - a. Bundles with 5 or less cables may use either bridle rings, J-hooks, or Arlington Loop.
- Submittals
 1. Cable bundles and supports

END SECTION 27 05 28

27 05 43 Underground Ducts and Raceways for Communications Systems - May 25, 2007

- Work in this section is open to any product or material.
- Requirements of Division 26 Electrical apply
- Section Includes
 1. Telephone service entrance raceway.
 2. Equipment and terminal backboards.
 3. Video service entrance raceway
- In the absence of other information, standards of the following organizations apply:
 1. Qwest Communications Inc.
 2. Comcast
- Materials Summary
 1. Telephone Termination Backboard:
 - a. Non-painted plywood
 - (1) Fire-retardant treated
 - (2) ¾" x 48" x 96"
 - b. Provided by General Contractor.
- Applications
 1. Elementary, Middle and High Schools
 - a. Two 4-inch conduits from pedestal to MDF for Qwest, with 200 pound calibrated mule tape, and 1-1/2" inner duct with 200 pound calibrated mule tape in innerduct.
 - b. One 2-inch conduit from pedestal to MDF for Comcast, with 200 pound calibrated mule tape.
 2. MDF to temp vault: One 4 inch conduit
 - a. Coordinate with Division 26 Electrical

END SECTION 27 05 43

27 05 53 Identification for Communications Systems - May 25, 2007

- Work in this section is open to any product or material meeting the requirements of this Technical Guideline.
- Labeling is required to clearly identify all components of the communications system (racks, cables, patch panels and outlets).
 1. The labeling system in the closets for backbone cable shall designate the cables origin and destination and a unique identifier for the cable within the system.
 2. Racks and patch panels shall be labeled to identify the location within the cabling system infrastructure.
 3. All labeling information shall be recorded on the as-built drawings and all test documents shall reflect the appropriate labeling scheme.
- The District's standard is to label each cable and face plate as follows:
 1. System Designation: "D" for data, "C" for video coaxial cable and "V" for voice in the first position of label.
 2. The second position denotes the closet where services originate.
 3. "0" represents the MDF and "1" represents the first IDF, etc.
 4. Thus the first voice cable in the "MDF" would read "V-0-01". The 60th cable would read "V-0-60".
 5. For data cables, the third position on the label represents the punch down number and is a consecutive number.
 - a. For example, the first data cable in closet "0" would have a label of "D-0-01".
 - b. The next data cable in that closet would be labeled "D-0-02" and so forth through all data cables.
 6. For voice cables:
 - a. First position would be "V" which shows that the cable and jack are voice.
 - b. The second position would be a "0" representing that was going to the "MDF" closet.
 - c. The third position would represent the number of where it was punched down on the station field in the closet.
- The cable shall be labeled behind the faceplate on a section of cable that is within 2-inches of the end of the cable and that can be accessed by removing the cover plate.
 1. The face plate shall be labeled with the corresponding number.

END OF SECTION 27 05 53

**Jefferson County School District, R-1 TECHNICAL GUIDELINES 2007
Division 27 – Communications**

27 06 00 Schedules for Communications - May 25, 2007

- Work in this Division is restricted to specific products of specific manufacturers that have been previously approved by Jefferson County School District, R-1 Telecommunications Department:

Description	MFG	Part Num.	Unit	Price
-------------	-----	-----------	------	-------

Station Cable (Copper) (Or approved equivalent product)

Cat 5E Blue CMP 4-pair, 350 MHz	AMP	57825-6	foot	
Cat 5E White CMP 4-pair	AMP	57825-2	foot	

Fiber Optic Cable

Fiber Optic Cable 12-Strand, MM, Armored, Plenum, 62.5 Micron Tight Buffer	N/A	N/A	foot	
Fiber Optic Cable 6-Strand, MM, Armored, Plenum, 62.5 Micron Tight Buffer	N/A	N/A	foot	

Backbone Voice Cable

100 Pair Voice Cable (CMP)	N/A	N/A	foot	
100 Pair Voice Cable (CMR)	N/A	N/A	foot	
25 Pair Voice cable (CMP)	N/A	N/A	foot	
25 Pair Voice cable (CMR)	N/A	N/A	foot	

Video Cable Plant (Or approved equivalent product)

RG6 Station Cable Quad-Shield, Plenum	Belden	6339Q8	foot	
---------------------------------------	--------	--------	------	--

Video Backbone Cable Plant (Or approved equivalent product)

RG-11, 60%, Plenum	Belden	6139B8	foot	
--------------------	--------	--------	------	--

Patch Panels & Fiber Enclosures (Or approved equivalent product)

Rack Enclosure, 12 port, loaded with ST Bulkheads	AMP	2-1206114-4	each	
Category 5E, 24-port	AMP	406330-1	each	
Category 5E, 48-port	AMP	406331-1	each	

Jacks and Connectors

Cat 5E Data Jack (orange)	AMP	406372-5	each	
Cat 3 (usoc) Voice Jack (Ivory)	AMP	406375-1	each	
Stainless steel wall phone faceplates (USOC)	SEMTRON	10EA5PHONEDP	each	
LightCrimp Plus "ST" Fiber Connectors, 62.5 Micron (equivalent products acceptable when pre-approved)	AMP	5492642-1	each	
ST Fiber Connector, 62.5 Epoxy/Polish (equivalent products acceptable when pre-approved)	AMP	5503571-3	each	

**Jefferson County School District, R-1 TECHNICAL GUIDELINES 2007
Division 27 – Communications**

Description	MFG	Part Num.	Unit	Price
Voice Blocks (equivalent products acceptable when pre-approved)	Suttle	SE66M1-50 C	each	
89 D Bracket (equivalent products acceptable when pre-approved)	Suttle	09-S89DS	each	
RG11 "F" Connectors	N/A	N/A	each	
RG6 "F" Connectors	N/A	N/A	each	

Patch Cords(Or approved equivalent product)

Enhanced Cat 5 (2 ft Green)	AMP	219243-2	each	
Enhanced Cat 5 (3 ft Yellow)	AMP	219246-3	each	
Enhanced Cat 5 (4 ft Blue)	AMP	219242-4	each	
Enhanced Cat 5 (6 ft White)	AMP	219245-6	each	
Enhanced Cat 5 (10 ft White)	AMP	1-219245-0	each	
Enhanced Cat 5 (12 ft White)	AMP	1-219245-2	each	
Optical Fiber, Patch Cord, "ST" Duplex, 1M, 62.5 (equivalent products acceptable when pre-approved)	AMP	5503994-1	each	
Optical Fiber, Patch Cord, "ST" Duplex, 3M, 62.5 (equivalent products acceptable when pre-approved)	AMP	5503994-3	each	

Faceplates and Inserts (Or approved equivalent product)

Double-gang 4 Port Faceplate (Almond)	AMP	83935-1	each	
Single-gang 4 Port Faceplate (Almond)	AMP	558088-1	each	
"ST" Connector Insert for Module, 62.5 Micron	AMP	1339123-1	each	
FLEX-MODE Faceplate (Almond)	AMP	558106-2	each	
Dual-gang SL Faceplate (Almond)	AMP	1339119-1	each	
Single-gang SL Faceplate (Almond)	AMP	1339118-1	each	
F-Connector Insert for Module	AMP	1499855-1	each	
"ST" Connector Insert for Module, MM	AMP	1339123-1	each	
Blank insert for Module (Almond)	AMP	1116412-1	each	
6 Pair Plenum 24-gauge	N/A	N/A	foot	
6 Pair PVC 24-gauge	N/A	N/A	foot	
6 Pair PVC 24-gauge, Speaker Wire	N/A	N/A	foot	

Classroom Ceiling Mounted Projector Cabling (Or approved equivalent product)

SL Series Faceplate, Single Gang	AMP	1339118-3	each	
SL Series Module, 2-Port Straight	AMP	1116409-3	each	
SL Series SVGA Module, 110 Termination	AMP	1479288-3	each	
SL Series RCA Multimedia Jack, 110 Termination, Red	AMP	1479230-3	each	

**Jefferson County School District, R-1 TECHNICAL GUIDELINES 2007
Division 27 – Communications**

Description	MFG	Part Num.	Unit	Price
SL Series RCA Multimedia Jack, 110 Termination, White	AMP	1479231-3	each	
SL Series RCA Multimedia Jack, 110 Termination, Yellow	AMP	1479232-2	each	
SLS-Video / 110 Termination	AMP	1375149-3	each	
SL Series Module, Blank	AMP	1116412-3	each	
Category 6 FTP Cable, Shielded Plenum (equivalent products acceptable)	AMP	4-1499416-3	each	
Miscellaneous Materials				
Surface-Mount Raceway	N/A	N/A	each	
Surface Mount Outlet Box	N/A	N/A	each	
Surface Mount Back Box	N/A	N/A	each	
Wall Caddy fasteners (equivalent products acceptable when pre-approved)	Lucent	AT90's	each	
19" X 84" Open Bay Rack	N/A	N/A	each	
4" Vertical Wire Management Rings	N/A	N/A	each	
Horizontal Wire Management	N/A	N/A	each	
Wire Management Rack Mounted Powerstrip	N/A	N/A	each	
12 Strand Fan-Out Kit	N/A	N/A	each	
Rack Grounding Kit to Bus Bar	N/A	N/A	each	
12" Ladder Rack, 10 ft	N/A	N/A	each	
Ladder Rack Mounting Kit	N/A	N/A	each	
Ladder Rack Wall Mounting Kit	N/A	N/A	each	
Caddy Saddles	Caddy	CAT425	each	
Viewsonics 8 Way Splitter Block (or approved equivalent product)	Viewsonics	VSD8WSP	each	
Plenum Saddles, Arlington Loop	N/A	N/A	each	
Bridle Rings	N/A	N/A	each	
J Hooks	N/A	N/A	each	

END SECTION 27 06 00

27 08 00 Commissioning of Communications General Cable Testing - May 25, 2007

- Work in this section is restricted to specific products of specific manufacturers that have been previously approved by Jefferson County School District, R-1 Telecommunications Services Department.
- See Section 27 06 00 – Schedules for Communications
- General Cable Testing

Jefferson County School District, R-1 TECHNICAL GUIDELINES 2007
Division 27 – Communications

1. All cables and termination hardware shall be 100% tested to detect defects in installation and to verify cable performance under installed conditions.
 2. All conductors of each installed cable shall be verified “useable” by the vendor prior to system acceptance.
 3. Testing can be completed by the installing contractor.
 - a. Third party testing is not required.
 4. Any defect in the cabling system installation including, but not limited, to cable, connectors, feed through couplers, patch panels, and connector blocks shall be replaced to ensure 100% useable conductors in all cables installed.
 5. All cables shall be tested in accordance with this document, and best industry practices.
 6. If any of these are in conflict, the vendor shall be responsible to bring any discrepancies to the attention of the District for clarification and resolution.
 7. Splicing of any type of communication cable is expressly prohibited.
 - a. Written exceptions will pertain to splicing fiber optic cable and RG61RG11 coax cable.
 - b. At the TPM’s request, these cables may be spliced in accordance with manufacturer’s recommendations and best industry practices.
- **Installation Warranty**
 1. The vendor shall warrant the cabling system against defects in workmanship for a period of one year from the date of system acceptance.
 2. The warranty shall cover all labor and materials necessary to correct a failed portion of the system and to demonstrate performance within the original installation specifications after repairs are accomplished.
 - **Cable Plant Warranty**
 1. Vendor will issue a warranty on installed cable plant, which warrants workmanship and all vendor installed components used in the system for one year from the date of acceptance.
 2. The warranty shall guarantee a minimum of 100 MHz for the horizontal copper, and the backbone copper.
 3. The backbone multimode optical fiber portions of the cabling system shall guarantee a minimum of 160 mHz.
 4. Copper links shall be warranted against the link performance minimum expected results defined in the ANSI/TIA/EIA 568A, TSB-67.
 5. Fiber optic links shall be warranted against the link and segment performance minimum expected results defined in the ANSI/TIA/EIA 568A, Annex H.
 - **Project Management/General**
 1. The single point of contact with the District is the PM who will be responsible for reporting progress and updating the District’s technical representative with issues that must be addressed to facilitate the cabling installation.
 2. Provide weekly written reports to the PM detailing progress.
 3. Requests for access to limited access or restricted areas shall be made the work day prior to the required access.
 4. Information critical to the completion of the task or project shall be communicated to the PM, as the requirement becomes known.
 5. Casual information shall be passed during the scheduled progress report.
 6. The vendor shall maintain the District facility in a neat and orderly manner during the installation of the cabling system.

Jefferson County School District, R-1 TECHNICAL GUIDELINES 2007
Division 27 – Communications

7. Designate acceptable staging and storage areas for materials.
 8. The District facility shall be maintained in an unobtrusive manner at the completion of each workday.
 9. At the completion of work in each area, the vendor will perform a final cleaning of debris prior to moving the installation crew to the next work area.
- **Copper Cable Testing**
 1. Testing can be completed by the installing contractor.
 - a. Third party testing is not required
 2. Each cable shall be tested for continuity on all pairs and/or conductors.
 3. Twisted-pair voice cables shall be tested for continuity, pair reversals, shorts, and opens.
 4. Twisted-pair data cables shall be tested for the all of the above requirements, plus tests that indicate installed cable performance.
 5. Test all cables with a cable tester verifying proper installation, continuity and cable length.
 6. The test shall be recorded as pass/fail as indicated by the test set in accordance with the manufacturers recommended procedures, and referenced to the appropriate cable identification number and circuit or pair number.
 7. Any faults in the wiring shall be corrected and the cable re-tested prior to final acceptance.
 - **Copper Data Cable Lengths**
 1. Each Category 5E cable shall be tested for installed length using an automated test type device.
 2. The cables shall be tested from patch panel to patch panel, block to block, patch panel to outlet or block to outlet as appropriate.
 3. The cable length shall conform to the maximum distances of 275 ft.
 4. Cable lengths shall be recorded, referencing the cable identification number and circuit or pair number.
 5. For multi-pair cables, the longest pair length shall be recorded as the length for the cable.
 - **Copper Performance Verification**
 1. Category 5E data cables shall be performance verified using an automated test set.
 2. Test results shall be automatically evaluated by the equipment, using the most up to date criteria from the ANSI/EIA/TIA standards for Category 5E.
 3. Test results shall be printed directly from the test unit or from a download file using an application from the Test equipment manufacturer.
 4. The printed test results shall include all tests performed, the expected test result and the actual test result achieved.
 - **Fiber Optic Testing**
 1. Testing can be completed by the installing contractor.
 - a. Third party testing is not required
 2. With respect to horizontal distribution multimode optical fiber, all terminations shall be tested in accordance with ANSI/EIA/TIA-568-B.3 H.
 3. Test evaluation for the panel to panel (backbone) or panel to outlet (horizontal) shall be conducted in accordance with ANSI/EIA/TIA-568-B.3 ANSI/EIA/TIA-526-14 for multi-mode fiber optic cable.

Jefferson County School District, R-1 TECHNICAL GUIDELINES 2007
Division 27 – Communications

4. All test jumpers will be the same fiber core size and connector types as the cable system.
5. When testing, the light source or OTDR must operate in accordance with ANSI/EIA/TIA-526-14A for multi-mode fiber optic cable.
- Video Cable Lengths and Terminations
 1. Each RG6 coax cable shall not exceed 300'
 2. Each RG11 coax cable shall not exceed 600'
 3. RG6 and RG11 coax cable shall terminate in either the MDF or corresponding IDF
 - a. Do not exceed stated maximum cable lengths
 - b. Terminate into 8 way splitters mounted on the wall
 4. RG11 coax cable shall be used for:
 - a. Backbone cabling
 - b. Broadcast return path in broadcast rooms
- Video Cable Testing
 1. Testing can be completed by the installing contractor.
 - a. Third party testing is not required
 2. Video coaxial cable shall be tested at 1 GHz. Backbone cable, RG-11 shall not exceed a loss value of more than 4.35db per 100 ft.
 3. Station cable, RG-6, and shall not exceed a loss value of 6.55db per 100 ft.
- Inspection Phases
 1. The TPM and PM will make periodic inspection of the project in progress.
 2. One inspection will be performed at the conclusion of cable pulling, prior to closing of the false ceiling, to inspect the method of cable routing and support, and the fire-stopping of penetrations.
 3. A second inspection will be performed at completion of cable termination to validate that cables were dressed and terminated in accordance with ANSI/TIA/EIA specifications for jacket removal and pair untwist, compliance with manufacturer's minimum bend radius, and that cable ends are dressed neatly and orderly.
- Final Inspection
 1. Upon completion of the project, the PM will perform a final inspection of the installed cabling system with the vendor's project foreman.
 2. The final inspection will be performed to validate that all horizontal and backbone cables were installed as defined in the drawing package, and that the installation meets the aesthetic expectations of the District.
- Test Verification
 1. Upon receipt of the test documentation, consisting of the printed test results of each cable tested, the District reserves the right to perform spot testing of a representative sample of the cabling system to validate test results provided in the test document.
 - a. Printed test results shall identify each cable tested and match installed cable designations.
 2. Any testing by the District will follow the same method employed by the vendor, and minor variations will be allowed to account for differences in test equipment.

Jefferson County School District, R-1 TECHNICAL GUIDELINES 2007
Division 27 – Communications

3. If significant discrepancies are found, the vendor will be notified for resolution.
- System Performance
 1. During the four-week period between final inspection and delivery of the test and as-built documentation, the District will activate the cabling system to validate operation of the cabling plant. This will be performed at the District's discretion.
- Final Acceptance
 1. Completion of the following will constitute acceptance of the system:
 - a. Installation; in-progress and final inspections;
 - b. Receipt of the test and as-built documentation;
 - c. Successful performance of the system for a four-week period

END SECTION 27 08 00

27 11 00 Communications Equipment Room Fittings - May 25, 2007

- Work in this section is restricted to specific products of specific manufacturers that have been previously approved by Jefferson County School District, R-1 Telecommunications Department.
- See Section 27 06 00 – Schedules for Communications
- General
 1. Racks shall be securely attached to the concrete floor using ½ inch bolt hardware.
 2. Racks shall be grounded to the telecommunications ground bus bar in accordance with current NEC codes, provided by Electrical Contractor.
 3. Left over rack mount screws (#12-24) not used for installing fiber panels and other hardware shall be screwed into the rack in open spaces for future use and left with the rack upon completion of the installation.
 4. Voice termination fields shall be mounted per Data, Communications and Alarm Diagram.
- Coordination
 1. All material will be supplied and installed by the Telecom vendor
- Voice Cross Connect
 1. The cross-connect for voice connectivity shall be a passive cross-connect between horizontal wall mount 66 block XC frames and backbone wall mount 66 block XC frames.
 2. Wire management frames shall be mounted between adjacent vertical frames to provide wire management of cross-connect wire.
 3. Wiring blocks, connecting blocks and horizontal “D” rings are to be installed as needed. Combinations of 25-pair frames shall be used as required by the horizontal and backbone pair counts to be terminated in a given closet.
 4. Frames shall be oriented so that backbone frames are located on the left and horizontal frames are located on the right of the termination field when facing the backboard.
 5. Cross-connects and cross-connect wire will be provided by District Telecommunications office.

6. The pinout for an RJ31x jack shall be as follows:

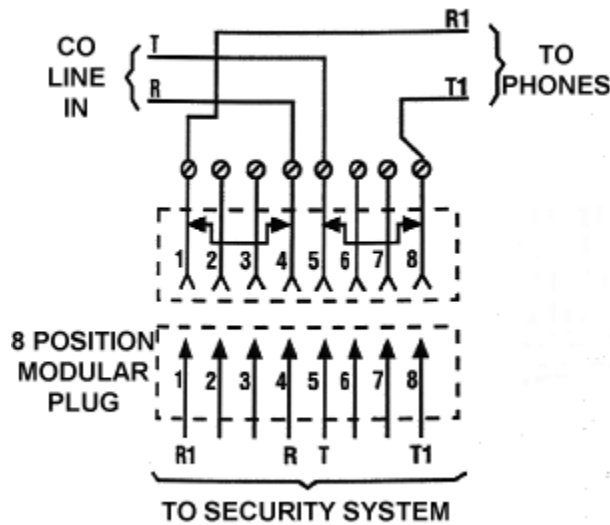

- Data Patch Panel (Provided by Telecom Vendor)
 1. Horizontal data cabling shall be connected using patch cords from the horizontal Category 5E termination panels to the network equipment within the same or adjacent racks.
 2. The horizontal data patch panel shall be contained in 19" x 7' rack(s).
 3. All equipment racks shall be augmented with horizontal and vertical management hardware, both front and rear, to properly dress horizontal cables and patch cords.
 4. Patch panels shall be 24 or 48 modular jack ports, wired to T568A.
 5. Patch panels shall be equipped with horizontal management panels (front) and cable support bars (rear), to properly dress, terminate and manage the installed cables and provided patch cords.
- Installation Requirements (by Telecom Vendor)
 1. Copper termination and management hardware shall be installed in the following manner:
 - a. Pair untwist at the termination shall not exceed one-quarter inch for Enhanced Category 5 connecting hardware.
 - b. Bend radius of the cable in the termination area shall not be less than 4 times the outside diameter of the cable.
 - c. Cables shall be bundled and dressed to their respective panels or blocks. Each panel or block shall be fed by an individual bundle separated and dressed back to the point of cable entrance into the rack or frame.
 - d. The cable jacket shall be maintained as close as possible to the termination point.
 - e. Each cable shall be clearly labeled on the cable jacket behind the patch panel.
- Communications Cable Management, Data Racks and Ladder Racks
 1. Provided by Telecom Vendor

Jefferson County School District, R-1 TECHNICAL GUIDELINES 2007
Division 27 – Communications

2. The telecommunication rooms shall have racks, voice termination fields and required cable routing hardware.
 - a. MDF shall have 2 racks, one for data and one for voice / WAN equipment
 - b. Each IDF shall have one rack
3. Racks shall be placed in a manner that will allow for clearance of 4 ½ feet in the back and 3 feet in front.
4. If one mounting rail of the rack is placed against a wall, the mounting rail shall be no closer than 6 inches to the wall to allow room for vertical management.
5. Multiple racks will be placed side by side with room for vertical wire management with 6 inches between wire management.
6. MDF and IDF layout must be reviewed and approved by TPM at DD, CD, and pre-construction.

END SECTION 27 11 00

27 13 00 Communications Backbone Cabling - May 25, 2007

- Work in this section is restricted to specific products of specific manufacturers that have been previously approved by Jefferson County School District, R-1 Telecommunications Department.
- See Section 27 06 00 - Schedule for Communications.
- Communications Copper Backbone Cabling
 1. The standard for voice backbone cabling shall be 24 AWG, 100-pair UTP, UL/NEC CMP rated.
 2. The District may change the size of voice backbone cable on a case-by-case basis.
 3. Cable shall be UL listed under file number E138034.
 4. A coupled bonding conductor will be installed within the riser bundle and bonded and grounded at each end if cable is running outside, where it is possible for a power induction into the cable.
- Communications Optical Fiber Backbone Cabling
 1. One orange 12-strand armored and plenum rated fiber optic backbone cable shall be installed from the data MDF to each of the IDFs, and will be plenum rated.
 2. Fiber cable: 62.5/125, 12-fiber multimode.
 3. A fiber warning label shall be attached every 24 feet.
- Fiber Installation Requirements
 1. Fiber slack shall be neatly coiled within the fiber termination panel. No slack loops shall be allowed external to the fiber panel(s).
 2. Each cable shall be individually attached to the respective termination panel by mechanical means. The cables strength member(s) shall be securely attached the cable strain relief bracket in the panel.
 3. Each fiber cable shall be stripped upon entering the termination panel and the individual fibers routed in the termination panel.
 4. Each cable shall be clearly labeled at the entrance to the termination panel. Cables labeled within the bundle shall not be acceptable.

Jefferson County School District, R-1 TECHNICAL GUIDELINES 2007
Division 27 – Communications

5. Dust caps shall be installed on the connectors and couplings at all times unless physically connected.
6. Of the 12 strands, 12 will be terminated with ST connectors on both ends.
- **Communications Coaxial Backbone Cabling**
 1. One RG-11 plenum rated coaxial cable shall be installed from the MDF to each of the IDFs, and will be jacketed as appropriate for use in a plenum environment.
 2. The cable distance shall not exceed 600 ft and shall have a maximum loss of 4.35 db per 100 ft when tested at 1Ghz.
 3. Each end of the cable shall be terminated with F style connectors.
- **Backbone Installation Requirements**
 1. Backbone cables shall be installed separately from horizontal distribution cables.
 2. Where cables are housed in conduit, the backbone and horizontal cables shall be installed in separate conduit.
 3. All cable (voice, data, fiber, and video) will be plenum rated unless specifically changed in writing by the Telecom Department.
 4. Where backbone and distribution cables are installed on a cable tray or wire way, backbone cables shall be installed on one side of tray and distribution cable shall be placed on the other side and bundled separately from the horizontal distribution cables.
 5. The District requires fiber to be installed using an armored plenum product; therefore, the use of inner-duct is not necessary.
- **Backbone Termination Hardware**
 1. Fiber optic cables shall be terminated in the data MDF and IDFs in rack mount patch panels providing protection to the terminated fibers.
 2. The enclosures shall provide AMP (or equivalent) “ST” interfaces. Rack mounted optical fiber enclosures shall support up to 12-ports in a one rack unit (1.75") space.
 3. Each patch panel shall have a slide out tray, which slides forward to allow easy access to the fibers for maintenance and installation.
 4. Voice backbone cables shall be terminated in wall mount 66 block XC frames. Wiring blocks shall be marked black every fifth pair.
 5. Combinations of 25-pair frames shall be used as required by the backbone pair counts to be terminated in the voice MDF.

END SECTION 27 13 00

27 15 00 Communications Horizontal Cabling - May 25, 2007

- Work in this section is restricted to specific products of specific manufacturers that have been previously approved by Jefferson County School District, R-1 Telecommunications Department.
- See Section 27 06 00 – Schedules for Communications.
- **Voice Communications Horizontal Cabling**
 1. Horizontal Category 5E plenum cabling as specified in Section 27 06 00 – Schedules for Communications..

Jefferson County School District, R-1 TECHNICAL GUIDELINES 2007
Division 27 – Communications

- Data Communications Horizontal Cabling
 1. Horizontal Category 5E plenum cabling as specified in Section 27 06 00 – Schedules for Communications.

END SECTION 27 15 00

27 16 00 Communications Connecting Cords, Devices and Adapters - May 25, 2007

- Work in this section is restricted to specific products of specific manufacturers that have been previously approved by Jefferson County School District, R-1 Telecommunications Department.
- See Section 27 06 00 - Schedules for Communications
- Telecommunication Outlets
 1. Each voice outlet location, unless otherwise noted, shall be implemented with one Category 5E cable.
 2. Each Category 5E cable shall be terminated on a 6-position, 6-conductor Category 5E RJ-11 jack, with “USOC” pin out.
 3. The outlet count at specific locations will be determined by the TPM and will be marked on the associated blueprints.
 4. Each CAT 5E cable shall be terminated on an 8-position, 8-conductor CAT 5E Universal jack to the T568A.
 5. Each RG6 coax cable shall be terminated on both ends with the appropriate F style connector.
 6. The outlet plates, unless otherwise noted, shall be mounted into single or dual gang boxes, box eliminators, surface mount boxes and floor monuments to be provided under the electrical sub-contractor.
- Modular Furniture Outlets
 1. Use appropriate AMP faceplate as determined by modular furniture manufacturer.
 2. The faceplate(s) shall be mounted in the appropriate knockout(s) in the furniture channel.
 3. The outlet count at specific locations will be determined by the TPM and will be marked on the associated blueprints.
- Wall Outlets
 1. Wall plates shall be front loading AMP Net-Connect Series.
 2. Each faceplate can contain two Category 5E jacks and two Category 3 jacks.
 3. Each terminated jack shall be provided with appropriate labeling to indicate the type of drop that it is and the MDF or IDF location.
 4. Faceplates labeling shall be covered by a clear plastic insert for each.
 5. AMP part numbers per Section 27 06 00.
 - a. Dual-gang Faceplate, almond
 - b. Single-gang Faceplate, almond
 - c. Blank, 1.5 Unit Module, almond
 - d. F-Connector Insert for Module
 - e. ST Connector Insert for Module
 - f. Blank Insert for Module

Jefferson County School District, R-1 TECHNICAL GUIDELINES 2007
Division 27 – Communications

- **Installation Requirements**
 1. Cables shall be coiled and supported in the ceiling if adequate space is present to house the cable coil without exceeding the manufacturer's bend radius.
 2. No cable shall be placed on ceiling tiles.
 3. No more than 12" of slack shall be stored in an in-wall box, modular furniture raceway, or insulated walls.
 4. Excess slack may be neatly coiled and stored in the ceiling above each drop location when there is not enough space present in the outlet box to store slack cable.
 5. Cables shall be dressed and terminated in accordance with the recommendations made in the ANSI/EIA/TIA-568A document, manufacturer's recommendations, and/or best industry practices.
 6. Pair untwist at the termination shall not exceed one-fourth inch for Category 5E connecting hardware.
 7. Bend radius of the cable in the termination area shall not be less than four times the outside diameter of the cable.
 8. The cable jacket shall be maintained as close as possible to the termination point.
 9. Voice jacks shall be located in the bottom position(s) of each faceplate.
 - a. Voice jacks in horizontally oriented faceplates shall occupy the left-most position(s).
 10. Data jacks shall occupy the top position(s) on the faceplate.
 - a. Data jacks in horizontally oriented faceplates shall occupy the right-most position(s).
- **Communications Patch Cords, Station Cords and Cross Connect Wire**
 1. See Section 27 06 00 - Schedules for Communications
 2. Patch cords used at the telecommunication rack and at the workstation shall be Enhanced Category 5, 24 AWG, 4-pair assemblies.
 3. Patch cords shall be factory-assembled by the manufacturer of the cabling system.
 4. Each workstation shall require one Enhanced Category 5 patch cord.
 5. The District shall provide the phone cords.
 6. In the IDF, 2, 3, and 4-foot patch cords shall be provided to cross-connect between the data patch panels and network equipment.
 7. One patch cord per installed outlet shall be provided by the Vendor.
 8. The total quantity of IDF end patch cords required is equally divided between three assembly lengths.
 9. In the workstation area, 6, 10, and 12-foot patch cords shall be provided in equal amounts of each length.
 10. Vendor provide attic stock of each size patch cord

END SECTION 27 16 00

27 31 00 Voice Communications Switching and Routing Equipment - May 25, 2007

- Work in this section is restricted to specific products of specific manufacturers that have been previously approved by Jefferson County School District, R-1 Telecommunications Department.
- Work in this section is typically provided by Jefferson County School District, R-1
- PBX/Key Systems
 1. The District communication standard for all equipment is based on the Nortel line of communication equipment.
 2. High Schools and specified sites shall be equipped with Nortel Opt. 11 PBX's.
 - a. The number of Cabinets will be determined by the port count of the school.
 - b. High schools and middle schools will be implemented with 1 QMOE (fiber) circuit to supply both voice and data.
 - (1) Four COTS trunks
 - c. The standard phone layout: 3904 H/F w/ Display for admin, and 8009 analog sets for classrooms.
 - d. The main answering position shall be augmented by Add On Modules for additional call handling capabilities.
- Elementary schools and specified sites shall be equipped with Nortel BCM.
 1. The quantity of station modules will be determined by number of stations needed.
 2. One networked DTI – T1 and four COTS trunks will provide connectivity to the Jeffco Schools network and the PSTN.
 3. The standard phone layout will be: 7324 for administrative areas, and 7208 sets for classroom applications.
 4. The main answering position shall be augmented by CAP modules for additional call handling capabilities.
- Internet Protocol Voice Switches
 1. The District Communication standard for all equipment is based on the Nortel line of communication equipment.
 2. For sites requiring Voice over IP, the specification is the Business Communications Manager, BCM 400 or the 1000M, depending upon site size.
 3. The exact card configuration will be determined by the specifics of the location.
 4. Connection to the PSTN and the District network will be provided either by a networked PRI or high bandwidth digital circuits (10 Mb minimum) and 2 COTS trunks.

END SECTION 27 31 00

Jefferson County School District, R-1 TECHNICAL GUIDELINES 2007
Division 27 – Communications

27 32 00 Voice Communications Telephone Sets, Facsimiles and Modems - May 25, 2007

- Work in this section is restricted to specific products of specific manufacturers that have been previously approved by Jefferson County School District, R-1 Telecommunications Department.
- Work in this section is typically provided by Jefferson County School District, R-1.
- Telephone Sets
 1. Option
 - a. 3904 Hands Free with Display Black
 - b. 2008 Basic Beige
 - c. 8009 Analog Beige
 2. Norstar / BCM
 - a. 7324 Beige
 - b. 7208 Beige
- Wireless Transceivers
 1. Not recommended
- Elevator Telephones
 1. A CAT 3 voice cable will be provided to elevator phone locations and an internal number will be provided.
 2. The actual phone and/or connection shall be made by the elevator subcontractor.
- Direct Dial Analog Service Emergency Telephones
 1. A Red 2500 Analog Set shall be provided to each school by the District.
- Facsimiles and Modems
 1. Typically excluded from the construction contract
- TTY Equipment
 1. Typically excluded from the construction contract.

END SECTION 27 32 00

27 33 00 Voice Communications Messaging - May 25, 2007

- Work in this section is restricted to specific products of specific manufacturers that have been previously approved by Jefferson County School District, R-1 Telecommunications Department.
- Work in this section is typically provided by Jefferson County School District, R-1.
- Voice Mail and Auto Attendant
 - a. The District provides centralized voice mail service.
 2. All Auto attendant features are supplied through the District provided centralized service.
- Interactive Voice Response
 1. Not applicable.
- Facsimile Servers
 1. Nortel Call Pilot:F

Jefferson County School District, R-1 TECHNICAL GUIDELINES 2007
Division 27 – Communications

- a. Fax server and stand alone fax machines procured directly by individual schools / departments.
- b. FAX machines should be capable of working in a Voice over IP trunk environment.

END SECTION 27 33 00

27 34 00 Call Accounting - May 25, 2007

- Work in this section is restricted to specific products of specific manufacturers that have been previously approved by Jefferson County School District, R-1 Telecommunications Department.
- Work in this section is typically provided by Jefferson County School District, R-1.
- Toll Fraud Equipment and Software
 1. Toll Fraud protection provided by Nortel Opt 81 programming and Call Pilot programming.
 2. All long distance calls require RBOC provided access codes.
- Telemanagement Software
 1. Optivity Telephone Manager in conjunction with Nortel Switch X-11

END SECTION 27 34 00

27 35 00 Call Management - May 25, 2007

- Work in this section is restricted to specific products of specific manufacturers that have been previously approved by Jefferson County School District, R-1 Facilities Services Department
- Work in this section is typically provided by Jefferson County School District, R-1.
- Digital Voice Announcers
 1. Voice announcements are provided by MIRAN card and Call Pilot Server
- Automatic Call Distributors
 1. Nortel Contact Center 6.0 in conjunction with X-4.5 succession software.
- Call Status and Management Displays
 1. Nortel – Symon, system monitoring product
- Dedicated 911 Systems
 1. X-11 Enhanced Services Administration working in conjunction with PS-ALI

END SECTION 27 35 00

27 51 13 Paging Systems – February 26, 2008

- Work in this section is restricted to specific products of specific manufacturers that have been previously approved by Jefferson County School District, R-1 Facilities Services Department.
 1. Bogen
 2. Simplex
 3. Valcom

Jefferson County School District, R-1 TECHNICAL GUIDELINES 2007
Division 27 – Communications

- Work in this section is included in the general construction contract.
- Coordination
 1. See Data, Communications and Alarm Diagram
 2. Section 26 05 19 Low Voltage Electrical Power Conductors and Cables
 3. Section 26 05 29 Hangers and Supports for Electrical Systems
 4. Section 26 05 53 Identification for Electrical Systems
 5. Section 26 08 00 Commissioning of Electrical System
- Submittals
 1. Product Data:
 - a. Required
 2. Shop Drawing: Required
 - a. MDF 66 block wiring diagrams with paging zone connections.
 - b. IDF 66 block wiring diagrams with paging interconnecting wiring diagrams of connections to the MDF.
 3. System wiring diagrams of all speaker locations and wiring routes used to connect each speaker.
 - a. Diagram must include identification of cable and wiring pair used at each speaker location and end termination.
 4. One line diagrams showing typical connections for all equipment in the paging system.
 5. Riser diagram for the system showing in technically accurate detail all connections, interconnections, and all provisions available and made for adaptability of all specified future functions and test data necessary to determine that all system components deliver the proper sound levels.
 6. Certificate of completion of installation and service training.
 7. Samples: As required
 8. Closeout:
 - a. Submittals listed above, updated to record status.
- Components
 1. PCM-2000 System manufactured by the Bogen Company:
 - a. Telephone Interface Module - PCMTIM
 - b. Central Processing Module - PCMCPU
 - c. 3-Zone Module - PCMZPM
 - d. System Amplifier - TPU-250
 - e. Uninterruptible Power System (UPS) - Triplite OmniPro
 2. Elementary/Middle Schools
 - a. 1 PCMTIM
 - b. 1 PCMCPU
 - c. 3 PCMZPM
 - d. 1 TPU-250
 - e. UPS Triplite OmniPro 1050
 3. High Schools
 - a. 1 PCMTIM
 - b. 1 PCMCPU
 - c. 3 TPU-250
 - d. UPS Triplite OmniPro 1400

Jefferson County School District, R-1 TECHNICAL GUIDELINES 2007
Division 27 – Communications

4. Paging speakers: Mixture of lay-in (ceiling), speaker/clock combinations, flush-mounted paging horns, surface-mounted paging horns, and wall-mounted speakers as required in the various locations:
 - a. Lay-in speakers: Valcom Clarity 521 (5 watt)
 - b. Speaker/clock combination speakers: Bogen S86T725
 - c. Flush-mounted speaker horns: Fourjay 416-TFASX
 - d. Surface-mounted speaker horns: Bogen SPT-15
 - e. Wall-mounted speakers: Bogen WBS58t725
5. Speaker wire: White, 6 pair Category 3, plenum rated, 24 AWG- solid conductor wires (Comtran 2628 or equal).
- Execution
 1. Each speaker shall be wired in the system by a continuous home-run to the MDF or IDF in the vicinity of the speaker.
 2. When speaker wires terminate in an IDF, extend to the MDF using the same a 25 pair cable.
 3. Install wire labels on both ends of each wire/cable installed.
 - a. Use Kroy or Brady brand self-adhesive wire markers.
 - b. Provide written documentation as to the origination and destination of each wire/cable.
 4. Terminate wiring from the speakers to the MDF and IDFs on the A-B side of a 66 block (AT&T 700A-66-B1- 25 Jack or equivalent) where they are first terminated.
 - a. Extend speaker wires that are first terminated in an IDF to the MDF from the C-D side of the block in the IDF to the A-B side of the 66 block in the MDF.
 - b. Then extend the speaker wires in the MDF from the A-B side to the C-D side of the 66 block using bridging clips (Siemens SA-1 bridging clips).
 - c. Connect the outputs from the Paging System ZPM modules to C-D side of the 66 block, grouping the speaker connections to the proper zone.
 - d. There must be a pair of paging system wires extended from the paging system location to the sound system equipment location in the gym, auditorium and the cafetorium for future use, not connected to the paging system but identified at each end.
 5. Paging speakers must all be set for 25 volt operation and adjusted or tapped for the following:
 - a. Hall speakers: 1 watt
 - b. Room speakers: ½ watt
 - c. Gym speakers: 15 watt
 - d. Cafeteria speakers: 2 ½ watt
 - e. Outside speakers: 7 ½ watt
 6. System Wiring shall be in a cable support path concealed above ceiling with drops at speaker locations.
 - a. Wiring for room speakers shall be stubbed above ceiling lines (at locations required with ¾" conduit) and install ¾" conduits through fire walls for wire chases.
 7. Install head end equipment in the MDF per Data, Communications and Alarm Diagram.

Jefferson County School District, R-1 TECHNICAL GUIDELINES 2007
Division 27 – Communications

- Quality Assurance
 1. The Contractor shall be an established communications and electronics contractor who has had and currently maintains a locally run and operated business for at least five consecutive years.
 2. The paging system must provide satisfactory sounds levels in all areas of the school, inside and outside, where installed.
 - a. It must be capable of processing paging inputs from the school's telephone system and from the system's administrative phone (direct connected) installed in the school's office area.
 - b. Elementary and Middle School systems must be capable of:
 - (1) Paging all speakers at the same time, and,
 - (2) Each of the 9 individual zones of the school (Zone Page), as identified by the District.
 - c. High School systems must only be capable of paging all system speakers at the same time
 3. Each speaker must have a separate continuous home-run connection (wiring pair) to the MDF or the IDF associated with the location of the speaker.
 4. Identify speaker locations on Construction Documents.
- System Testing
 1. Provide all required testing apparatus and factory-trained personnel specified to successfully complete the test.
 - a. No third party testing is required.
 2. Prior to energizing or testing the system, ensure the following:
 - a. All products are installed in a proper and safe manner per the manufacturer's instructions.
 - b. Insulation and shrink-tubing are present where required.
 - c. Dust, debris, solder splatter, etc., are removed
 - d. Cable is dressed, routed and labeled, connections are consistent with requirements
 - e. All labeling has been provided
 - f. Electronic devices are properly grounded
 3. 25V Speaker Test:
 - a. Play music or other distinctive audio signal through all speakers.
 - b. Walk all rooms and other speaker locations.
 - c. Verify that each speaker is operating and that there are no significant changes in volume levels from one speaker to the next.
 - d. Verify that the extent of coverage is consistent with the areas indicated on the drawings.
- Commissioning
 1. Train Owner's maintenance personnel in the procedures and schedules involved in operating, troubleshooting, and preventive maintenance of the system.
 - a. Provide one 2-hour training session by a manufacturers' qualified representative.
 2. Train school staff (administrators, custodians, secretaries) on proper use of the system which covers operation using the telephone system and the administrative phone.
 - a. Provide a minimum of two (2) 1 hour sessions.

Jefferson County School District, R-1 TECHNICAL GUIDELINES 2007
Division 27 – Communications

- b. Space the training at least 2 or 3 week intervals.
- c. Schedule all training sessions through the District Project Manager, with at least (7) seven days advanced notice.
- Warranty
 1. All materials and installation shall be guaranteed to be free from defects in material and workmanship after final acceptance of installation, for the period defined in the provisions of Division 01.
 - a. Make a minimum of 3 on-site visits to make system adjustments when requested during the first year of completion.
 - b. On premise maintenance shall be provided at no cost to the purchaser, unless damage or failure is caused by misuse, abuse, neglect, accidents, or other items beyond installer's control.

END SECTION 27 51 13

27 51 16 Public Address and Mass Notification Systems - May 25, 2007

- Work in this section is restricted to specific products of specific manufacturers, by model number, that have been previously approved by Jefferson County School District, R-1.
- Section Includes:
 1. Public Address; Independent sound system for public performances and meetings in the:
 - a. Gymnasium
 - b. Multipurpose room
 - c. Auditorium
 - d. Vocal Music
 - e. Instrumental Music
 - f. Commons
 - g. Cafeteria
- See Data, Communications and Alarm Diagram.
- In the absence of other information, standards of the following organizations apply:
 1. Electrical Components complying with applicable requirements of NFPA 70 "National Electrical Code" including, but not limited to:
 - a. Article 250, Grounding
 - b. Article 300, Part A., Wiring Method
 - c. Article 310, Conductors for General Wiring
 - d. Article 725, Remote Control, Signaling Circuits
 - e. Article 800, Communications Systems
 2. Underwriters Laboratories (UL) 50 as applicable.
- Submittals
 1. Product Data: Required
 - a. Equipment prints
 - b. Full electronic wiring diagrams
 - c. Specification sheets including cable types.
 2. Shop Drawings: Required

Jefferson County School District, R-1 TECHNICAL GUIDELINES 2007
Division 27 – Communications

- a. Detailed wiring diagrams for power, signal and control that clearly differentiate between manufacturer installed wiring and field installed wiring.
 - b. Identify wires at termination points to facilitate installation, operation and maintenance.
 - c. Detail programmable electronic communications network system including but not limited to the following:
 - (1) Detailed One Line Drawings
 - (2) Equipment Cabinet Arrangement
 - d. System field wiring diagrams showing typical connections for all equipment.
 - e. Manufacturer's complete service notes and drawings detailing all interconnections.
 - f. Riser diagram for the system showing in technically accurate detail all connections and interconnections.
3. Test Reports: Required
- a. Include calculations, charts and test data necessary to demonstrate that the system components deliver the specified signals and power levels at the required points and locations.
4. Certificates: Required
- a. Copy of UL listing cards for the proposed system
 - b. A signed statement from the equipment supplier that the system has been wired, tested and functions properly according to the specifications.
5. Manufacturer Instructions: Required
- a. Four copies of complete operational instructions shall be furnished complete with record drawings.
 - b. Include part numbers and names, addresses and telephone numbers of parts source.
6. Manufacturer Field Reports: Required
7. Commissioning:
- a. Submittals listed above, updated to record status.
 - b. Demonstration and training:
 - (1) Provide a factory authorized representative to present a 2-hour demonstration on site to the school staff about the major features, common functions and routine operation of each component.
 - (2) Present one in-depth 2-hour session of technical classroom training, on-site, by a factory trained representative of the equipment manufacturer for selected District technicians on the functions, trouble diagnosis and proper maintenance of the installed equipment.
 - (3) Furnish each member of the class a copy of the manufacturers' applicable training manuals.
 - (4) Schedule the demonstration and training sessions with the District project manager at least ten days in advance.
 - c. Warranty
 - (1) Guarantee all materials and installation to be free of defects in material and workmanship after final acceptance of installation for the period defined in the provisions of Division 01.
 - (2) Provide on-the-premise maintenance at no cost for the warranty term.

Jefferson County School District, R-1 TECHNICAL GUIDELINES 2007
Division 27 – Communications

- (3) Within one year of date of acceptance, provide up to three on-site assistance visits to adjust sound levels, reset matching transformer taps and adjust controls to suit actual occupied conditions.
- Maintenance
 1. Local service by factory-trained personnel of the specified equipment from an authorized distributor of all equipment specified under this section.
 - Amplifier
 1. Crown Dual Channel
 2. No greater than 15 inches wide, 5 inches high and 26 inches deep.
 3. Audio output of a minimum of 250 watts RMS with a total harmonic distortion of .05% maximum at 1 kHz rated power.
 - a. Output regulation .5 dB (direct); 1.0 dB (Transformer).
 4. Amplifier must meet load requirements
 - Mixers
 1. BIAmp, 8 channel
 2. Complete input and mixing facilities for 8 low impedance microphone inputs and auxiliary inputs with selectable priority channel.
 3. Output of system is not to be mutable at either the input or output
 4. Auxiliary programs input such as CD players and recorders are considered as part of this guideline.
 - a. Include CD player and recorder combination with remote control (IR).
 - (1) Product previously approved by Jefferson County School District, R-1 is Marantz PMD with the IR control.
 5. Complete input and mixing facilities for microphone inputs and auxiliary inputs
 - a. Input overload circuit which permits microphone signals of up to 1 volt to be reproduced without any discernible increase in distortion.
 - b. Capable of reproducing microphone signal levels above 1 volt magnitude without overloading; or rely upon a gain switch to accommodate high signals
 - c. Interrupt capability to permit input on priority channel to override PA system.
 - Signal Processor: Shure DFR22EQ
 1. Include all circuitry and controls necessary to provide complete system equalization for optimum sound reproduction and maximum gain before feedback.
 - a. Equalizer filters: 1 octave bandpass type having an individual range of 12 dB.
 - b. Front and back panels will have user lockout controls.
 - Speakers:
 1. Sound Tube HPi12, HP 8i, HP8iCM, or CM 600i, or District approved equal.
 - a. Monitors: EV-SX300/MB200 or District approved equal.
 2. Self-contained loud speakers manufactured by manufacturers previously approved by Jefferson County School District, R-1.
 3. Numbers of speakers used depend on the physical area to be covered.
 4. All hanging speakers will have a minimum of two support cables, rated to support 10 times the speaker weight.

Jefferson County School District, R-1 TECHNICAL GUIDELINES 2007
Division 27 – Communications

5. All Gymnasiums will have hanging speakers manufactured by Sound Tube and the model will depend on the area to be covered.
- Microphones:
 1. Handheld microphones:
 - a. Shure SM58LC
 - b. With stand and 25 foot microphone cable each.
 2. Wireless microphones systems:
 - a. Shure PGX 24/SM58 or ATW 3000 series.
 - b. Two (2) per stage and gymnasium.
 3. Hanging microphones:
 - a. Shure MX 202BP/C
 - b. Three (3) per stage.
 4. Microphone jacks:
 - a. Switchcraft Model D3FD
 - b. Flush mounted.
- Power Conditioner and Sequencer
 1. Furman Model PS-PRO Series 11
 - a. Keyed off/on switches
 - b. Standard rack mountable
- Cables
 1. Speaker Circuits
 - a. Homerun station wiring in individually jacketed cables
 - b. Cables 18 AWG conductors; plenum rated
 2. Microphone cables:
 - a. Minimum of 22 AWG, plenum rated and each jack homerun to sound cabinet
 3. All microphone jacks will be Switchcraft Model D3FD or District approved equal.
- Equipment Rack:
 1. Lowell L260-36/L2150-36;
 - a. Floor mount with front locking door
 - b. Louvered front and back doors
- Source Quality Control
 1. Listed by Underwriter's Laboratories under UL Standard 1459.
 2. All items of equipment, including wire and cable, shall function as a complete system.
 3. Experimental equipment will not be acceptable.
 4. The proposed system must be demonstrable at a local customer's facility.
- Execution Summary
 1. Install system in a well ventilated location with adequate heat rejection and in accordance with NFPA 70, other applicable codes, and manufacturer's written instructions.
 2. Provide necessary transient protection on the AC power feed to the system.
 3. Install low voltage wiring within cable supports above accessible ceilings and in raceways where Inaccessible or in exposed areas.
 4. Install in conduit within inaccessible ceiling and wall spaces.
 5. Use UL listed plenum cable.

Jefferson County School District, R-1 TECHNICAL GUIDELINES 2007
Division 27 – Communications

6. Do not install system cabling and high voltage wiring within the same raceway.
 7. Carefully match input and output impedances and signal levels at signal interfaces.
 8. Provide matching networks where required.
 9. Provide adequate length of conductors within enclosures.
 10. Neatly bundle, tie and trim the conductors to terminal points with no excess.
 11. Provide 12 inch minimum separation between cables to speaker-microphones and adjacent parallel power and telephone wiring.
 12. Make splices, taps and terminations on numbered terminal punch blocks in junction, pull and outlet boxes, terminal cabinets and equipment enclosures.
 13. Use color coding of conductors and apply wire and cable marking tape to designate wires and cables so all media are identified in coordination with system wiring diagrams
 14. Cable supports are mandatory where routed through plenum ceiling areas.
 - a. See Data, Communications and Alarm Diagram.
- **Grounding**
 1. Equipment grounding connections are required for communications network systems rack.
 2. Tighten connections to comply with tightening torques specified in UL Standard 486A to assure permanent and effective grounds.
 3. Ground equipment and cable shields to eliminate shock hazard and to minimize to the greatest extent possible ground loops, command mode returns, noise pickup, cross talk and other impairments.
 - **Acceptable Installer**
 1. Installation and start up are required to be under the direct supervision of a local contractor meeting the following criteria:
 - a. Regularly engaged in installation, repair and maintenance of such systems.
 - b. Established sound systems, communications and electronics contractor that has had, and currently maintains, a locally run and operated business for at least five years.
 - c. Local authorized distributor of all specified equipment for a single source of responsibility and shall provide documents proving such.
 - d. Provide written proof that his firm is adequately staffed with factory-trained technicians for all of the specified equipment.
 - **Acceptable Supplier**
 1. Factory authorized distributor meeting the following criteria:
 - a. Full responsibility to honor the manufacturer's warranty.
 - b. Show satisfactory evidence, upon request, that the supplier maintains a fully equipped service organization capable of furnishing adequate inspection, training and service to the system.
 - c. Availability of necessary spare parts in the proper proportion as recommended by the manufacturer to maintain and service the equipment being supplied.
 - d. Accredited by the proposed equipment manufacturer(s) and prepared to offer a service contract for system maintenance on completion of the warranty period.

Jefferson County School District, R-1 TECHNICAL GUIDELINES 2007
Division 27 – Communications

- e. Provide the names, locations and cite five recent successful installations in the area.
- **Field Quality Control**
 1. Provide the services of a factory authorized service representative to supervise the field assembly, connection of components and the testing and adjustment of the system.
 2. Check-out and final connections to the system shall be made by a factory trained technician in the employ of the manufacturer of the products installed.

END SECTION 27 51 16

27 53 13 Clock System - May 25, 2007

- Work in this section is restricted to specific products of specific manufacturers that have been previously approved by Jefferson County School District, R-1 Facilities Services Department.
 1. Master Clock:
 - a. Lathem LTR-8-512M with modem
 2. Remote Selector Switch:
 - a. Lathem LTR-RSS
 - b. Locate in Main Office adjacent to Fire Alarm Control Panel.
 3. Slave Clocks:
 - a. 120 volt operation/120 volt correction
 - b. 12" (classrooms, offices, etc) Lathem #SS12RFA120, round, black finish, flush 12 hour dial
 - c. 15" (gym) Lathem #SS16RFA120 round, black finish, 12 hour dial
 4. Gym Wall Clock Wire Guard:
 - a. Carrier Current Technologies, #3040-16
 5. Wall Clock/ Speaker Back Box (combo) & Finish Cover (grey):
 - a. Carrier Current Technologies 3052-12F
 6. Slave Clock Back Box (flush mount) for single clock:
 - a. Carrier Current Technologies #3050
 7. 10" Outside Bells (120) volt:
 - a. Carrier Current Technologies #5010-120
 8. Vandal Cover (10" bell):
 - a. Carrier Current Technologies #5000-02
- See Data, Communications, and Alarm Diagram.
- **Submittals**
 1. Product Data: Required
 2. Shop Drawing:
 - a. Required
 - b. Provide a complete one-line wiring schematic showing all elements of the central clock system including all wiring, cable and conduit.
 3. Design Data: Required
 4. Acceptance Test Report: Required
 5. Manufacturer Instructions: Required

Jefferson County School District, R-1 TECHNICAL GUIDELINES 2007
Division 27 – Communications

6. Manufacturer Field Reports: Required
7. Closeout:
 - a. Submittals listed above, updated to record status.
 - b. Operation and Maintenance Manuals:
 - (1) Include instructions for local and remote programming of the system.
 - c. Demonstration and training
- Parts and Service:
 1. Local representative and factory authorized local service organization must carry a complete stock of parts and provide maintenance for the system.
 2. Both the manufacturer and the service organization are required to have at least five years experience within a seventy five-mile radius of the Denver metro area.
- Training:
 1. Fully instruct and train the Owner's operating personnel in the proper operation and maintenance of the clock and bell network.
 2. Provide two hours of system demonstration on the job site and at least two additional hours of technical classroom training on the programming and proper maintenance of the components.
- Provide a complete, synchronous programmable central clock system with the following features:
 1. 120V AC System
 2. Correct all secondary (slave) clocks once each hour from a separate correcting circuit, NOT from a signal via the power wiring.
 3. Secondary clocks operate by individual synchronous motors which are connected to 120VAC, 3 conductor wiring originating from the master clock.
- Master clock:
 1. Microprocessor-based solid state circuitry.
 2. Units which require factory programming or special tools such as diodes, etc., are not acceptable.
 3. Eight circuits (minimum) each rated for 120 VAC, 10 Amps
 4. Program memory: electrically alterable with 7 day standby battery backup.
 5. 40% spare power output capacity for future devices.
 6. Locate in MDF in a semi-recessed cabinet with a lift-off front panel.
 7. See Data, Communications and Alarm Diagram.
- Master Clock Programming
 1. Each circuit capable of being scheduled for time of day, day of week, and automatic holiday routines.
 2. Possible to make a minimum of six programmed schedule changes locally from the key pad or remotely via a computer, software, modem, communication port and card.
 3. Automatically correct for daylight savings time.
 4. Either local or remote programmable using a key pad, a RS-232 communication card and port, software for a remote computer, an LCD display and a compatible telephone modem.
- Acceptable Installers
 1. Contractor must be certified by the manufacturer to install and maintain the system.

Jefferson County School District, R-1 TECHNICAL GUIDELINES 2007
Division 27 – Communications

2. Provide a list of projects of similar complexity installed and maintained by their firm within the last five years.
- Field Quality Control
 1. Perform a final system acceptance test in the presence of Jefferson County School District personnel.

END SECTION 27 53 13

Responsibility Matrix

Task	Paging System					
	CA	PM	CS	FM	A&E	GC
Validate Existing System				S		P
Develop Specification	P		P	P	P	
Plan Review	P	P	P	P		
Product Submittal Review			S		P	P
Pre-Installation Meeting		P	P	P	P	P
Day One Install			P	S		P
Periodic Inspection	S	P	P	P	P	
Rough In	S	P	P	P	P	P
Contractor End-to-End Test			S	P	P	P
Final Inspection				S	P	P
System Certification	P	P		S		
Agency Inspections						P

Task	Fire Alarm System					
	CA	PM	CS	FM	A&E	GC
Validate Existing System				S		P
Develop Specification	P		P	P	P	
Plan Review	P	P	P	P		
Product Submittal Review			S		P	P
Pre-Installation Meeting		P	P	P	P	P
Day One Install			P	S		P
Periodic Inspection	S	P	P	P	P	
Rough In	S	P	P	P	P	P
Architectural - Annunciator Final Drawings	S				P	P
Contractor End-to-End Test			S	P	P	P
Final Inspection				S	P	P
System Certification	P	P		S		
Fire Department Checkout		S	S	S	P	P
Agency Inspections						P

Jefferson County School District, R-1 TECHNICAL GUIDELINES 2007
Division 27 – Communications

Task	Telecomm					
	CA	PM	CS	TC	A&E	GC
Validate Existing System				S		P
Develop Specification	P		P	P	P	
Plan Review	P	P	P	P		
Product Submittal Review			S		P	P
Pre-Installation Meeting		P	P	P	P	P
Day One Install			P	S		P
Periodic Inspection	S	P	P	P	P	
Rough In	S	P	P	P	P	P
Architectural - Annunciator Final Drawings	S				P	P
Contractor End-to-End Test			S	P	P	P
Final Inspection				S	P	P
System Certification	P	P		S		
Fire Department Checkout		S	S	S	P	P
Agency Inspections						P

Legend:

P = Primary Participant - Must Attend

S = Secondary Participant - May Witness

CA = Coordinating Architect

PM = Project Manager

CS = Commissioning Specialist

FM = Facility Maintenance

TC = Telecom

A&E = Architect/Engineer of Record

GC = General Contractor

END RESPONSIBILITY MATRIX